

The Non-Wireless Part of Cellular Networks: What's With the Backhaul?

Peter D. Magill and Byoung-Jo "J" Kim

AT&T Labs - Research, Rm. A5-1B33, 200 Laurel Ave., Middletown, NJ 07748 USA, pete@research.att.com

Abstract: The wireline backhaul of cellular networks plays a critical role in connecting cells to the rest of the telecom world and to each other. As the radio and air interfaces have evolved, so too has the backhaul. The architectures and transport technologies used for wireless backhaul in the US will be described.

OCIS codes: (060.0060) Fiber optics and optical communications; (060.4250) Networks

1. Introduction

Cellular communication is most useful when it is nearly ubiquitous, especially given customer preference for mobility in the USA today. And in some other countries, cellular is being readily adopted in place of landline because of the relative speed and ease of installation. In the United States there are ~100,000 cell towers¹ today. With multiple wireless carriers operating at most of them, there is a need to bring traffic "back" (backhaul) from ~250,000 base station sites² to the larger network. These carriers have a variety of different options from which they can choose to meet their backhaul needs, depending on their particular business plans. For example, a wireless carrier could choose to build its own dedicated network (wireline or wireless) to backhaul signals from its cell sites to connect them to the traditional telephony network (for voice) and the Internet (for data). Or the carrier could purchase backhaul services from one or more providers of dedicated transmission services – including, *inter alia*, the incumbent local exchange carrier (ILEC), one of multiple competitive local exchange carriers (CLECs), providers of fixed-wireless services and/or CATV companies.

2. Business Conditions and Regulation

Historically in the United States, wireline telephony services have been regulated pervasively by the federal and state governments while wireless services have been subject to less regulation. Several categories of entity operate wireline networks in the US. One category includes the group of companies that are successors to AT&T after its breakup in 1984 [i.e., the seven Regional Bell Operating Companies (RBOCs) and a long-distance operator (AT&T)] and all the subsequent mergers and acquisitions between those companies, plus other entities, such as GTE, as well as some 1300 generally small independent rural companies. A second category includes the many CLECs who have arisen since regulatory liberalization of US telecommunications in the 1990s. These carriers typically have focused on serving urban areas and suburban office parks where demand is concentrated, but, in some cases, have built out their networks in other areas in response to demand. A third category that has emerged as a strong competitor in this space consists of the CATV companies, that have long provided close-to-ubiquitous cable television services throughout urban, suburban and even rural locations. These providers have grown substantially in the past several years, and have set their sights on wireless backhaul as a burgeoning business opportunity. And a fourth consists of fixed-wireless providers, which are the dominant providers of wireless backhaul services in much of the world, but have played a less significant role in the United States because of the low cost of legacy T-1 services in this country. Thus wireless carriers may decide for a number of reasons (e.g., competitive concerns, economic concerns) to purchase these services from a CLEC, CATV or fixed-wireless provider or to build their own access link to a cell site and avoid using the available local wireline services.

3. Cell-Site Backhaul Link Architectures

As shown in Figure 1, this paper describes only that portion of the backhaul from the cell site to the first office with switching equipment for that cellular carrier's network, typically called a Mobile Telephone Switching Office (MTSO). The equipment used for the backhaul has evolved to match both the needs of the base station technology and the most cost-effective metro transport at the time. The so-called first generation (1G) service (first deployed in 1983) was for voice telephony only. It used an air-interface technology called the Advanced Mobile Phone System (AMPS) which was designed to inter-operate easily with the existing TDM-based public-switched telephone network (PSTN). Thus the most cost-effective metro backhaul used T1 lines (1.544 Mb/s, over a variety of copper infrastructure). This T1 connection carried a private-line service from the network terminating equipment (NTE) at the cell site to the NTE in the MTSO. En route between these points, the signal potentially passed through one or more central offices of the local landline carrier and was possibly multiplexed with other T1s (using a digital cross-connect system or DCS). Within the carrier's MTSO, the signal was connected to a Base Station Controller (BSC)

which then connects to a Mobile Switching Center. The T1 data rate was adequate for a typical 1G base station with three sectors (supporting ~30 voice channels). AT&T has retired all AMPS from its Mobility network. One operator in Canada still operates an AMPS network.

There are two main air-interface standards used for 2G, Global System for Mobile communications (GSM³) which first went into service in 1991 for voice with General Packet Radio Service (GPRS) for data (and later Enhanced Data rates for GSM Evolution or EDGE), and Code-Division Multiple Access (CDMA or IS-95⁴) for both voice and data, first standardized in 1995. The data services are largely intended to serve vertical applications and limited or reformatted Internet content. While these air-interface technologies are very different, their backhaul arrangements are similar. Each 2G-cell generally handles more voice calls than the 1G, plus they support limited data calls, and thus require more than 1.5 Mb/s of backhaul capacity. Since the voice is TDM, and the data is encapsulated in asynchronous transport mode (ATM) cells, the most cost-effective backhaul uses multiple T1s, some carrying the voice signals and others carrying ATM cells encapsulated into T1 payloads. In the metro transport network, T1s are economically multiplexed into higher rate signals (e.g., DS3 or SONET STS-1) before being terminated on a BSC in the Mobile Office. Within the BSC, the voice and data signals are separated, where voice is routed to the PSTN and data is routed to the Mobile Data Network which, through a series of routers and gateways, eventually connects to a Tier 1 Internet Service Provider (ISP).

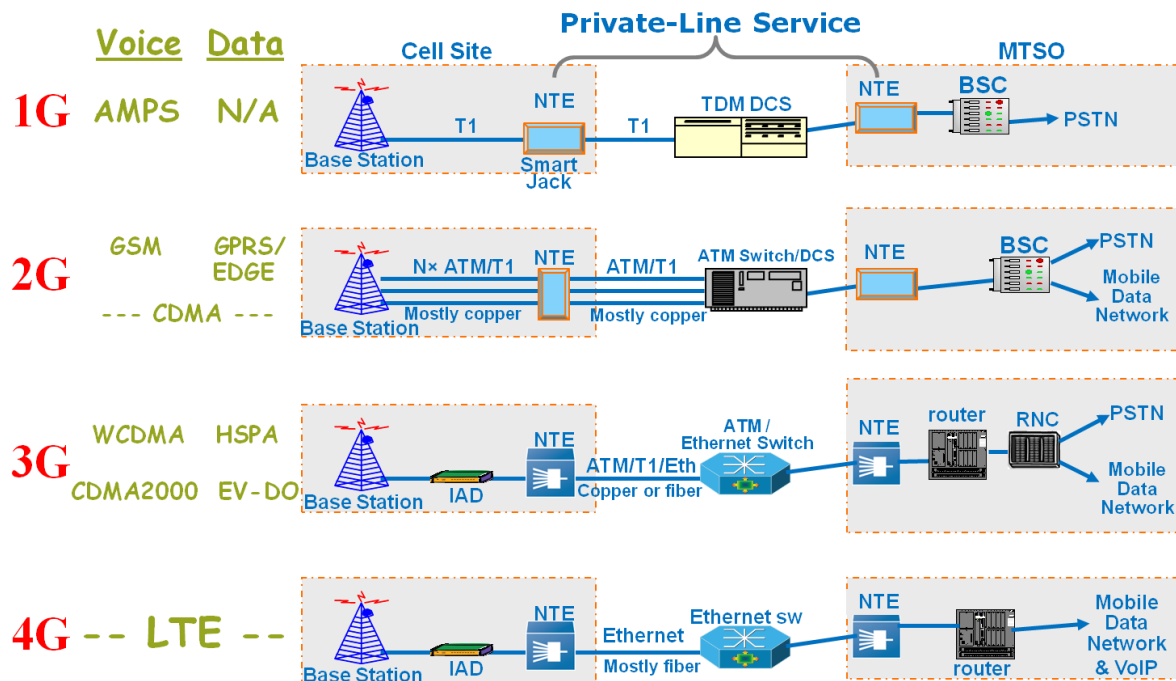

Figure 1. Typical backhaul architectures for each of the four cellular technology "generations."

There are also two air-interface technologies generally used for 3G, Wideband Code-Division Multiple Access (WCDMA⁵) for voice with High-Speed Packet Access (HSPA) or CDMA2000⁶ for voice with Evolution-Data Optimized (EV-DO) for data. Their backhaul arrangements are similar, like the 2G situation. The connections begin at an Integrated Access Device (IAD) at the cell site. The IAD is used to multiplex signals from multiple 3G sectors into a single packet stream. The backhaul link connects the IAD to the MTSO. For 3G the IAD encapsulates all data in ATM cells for transport over the backhaul link. However, even though the 3G signals to be backhauled are packet-based, in most areas little or no packet-based metro network existed prior to 2010. Therefore, the IAD can perform a variety of format conversion and encapsulation of ATM over whichever transport signal is available [e.g., T1, 100 Mb/s Fast Ethernet (FE) over copper, or GigE over fiber]. After the NTE in the MTSO, all signals pass through an IP router (sometimes known as a Mobile Service Node or MSN) to the Radio Network Controller (RNC) (or similarly the BSC for CDMA2000) to be passed along to either the PSTN or the Mobile Data Network, as appropriate. 3G uses a centralized architecture, where the RNC controls many details of the 3G air interface for cells under its control, such as transmit power levels, modulation formats, soft-combining, and retransmission. Plus, the RNC is involved in the hand-offs of a call from one cell site to another as the user moves and/or conditions change. The recent success of smartphones and the general increase in Internet usage has increased the need for higher-speed

backhaul for many carriers. Backhaul upgrades can take longer than improvements in the air interface, and have sometimes become the bottleneck for the overall user experience. This situation is being rapidly remedied in the US.

Finally, the next wireless technology is known as Long-Term Evolution (LTE⁷) which will be used for the fourth generation (4G) by most of the dominant cellular carriers. However, WiMAX⁸ is also used as an alternative 4G technology by some carriers. WiMAX and LTE do not inter-operate, but they use many of the same fundamental radio techniques to achieve similar spectral efficiencies and coverage for similar carrier frequencies.

The LTE standard covers technologies to be used for both voice and data services. In fact, the voice signals will be packetized according to the voice-over-Internet-protocol (VoIP) standards (adapted to cellular environments), and so from a backhaul perspective, all signals to be transported will be in IP packets. An IAD is used again at the cell site to multiplex, format convert and manage the variety of signals from the base stations, presenting them all on a single GigE connection to the NTE. The expected increase in data demand over the next few years makes GigE over fiber the preferred connection to the metro network, but in some instances Ethernet over copper will be used, even for new builds as well as fixed-wireless links. The rest of the backhaul link is very similar to that of 3G, to a network of IP routers and then on to the Mobile Data Network and VoIP gateways and switches.

Now Fig. 1 is depicted with each technology generation shown separately, for pedagogical reasons. But it does not describe real-world deployments accurately. Because of the buying behavior and expectations of end-users, many of these technology generations must co-exist for many years. So nearly all cell sites today have at least a 2G- and one or more versions of 3G-technology, *per wireless carrier*, all operating simultaneously. And, as LTE is turned up, those signals will also need to be backhauled with the others. This amalgamation of networks has two implications: 1. The IAD is more useful because it will multiplex signals from all technology generations together, as well as the multiple signals for each, and 2. the data rate required of the backhaul is initially greater, even for a given number of users and usage pattern, because of the inefficiency caused by having some users on one technology and some on another. However, this is an evolution in progress. The number of users will gradually decline on the older technologies, decreasing the data rate needed while the number of users gradually increases for the newer technologies. And these transitions will happen at different rates and times from one cell site to another. Managing the growth of the full backhaul network for all of this traffic in an economical fashion can be quite a challenge.

Finally, the description above is intended to describe the typical arrangements used for most cell sites. But of course there are numerous exceptions. In some cases a wireless carrier will find it more economical to build their own facilities to a cell site rather than use a leased line from local wireline carriers. Or it may be more economical to use point-to-point radio links for the backhaul because they require no trenching and burying and have many fewer right-of-way issues.

4. Conclusion

We have summarized some of the regulatory, technology and business conditions in the United States which drive the decisions of the wireless carriers. We then described, at a high level, the typical cell-site backhaul architectures for each of the four major air-interface "generations." For a more detailed explanation of the numerous wireless technologies consult the International Telecommunication Union⁹ (ITU).

We wish to thank Bob Doverspike of AT&T Labs – Research for his assistance with this paper.

5. References

¹ http://www.wirelessestimator.com/t_content.cfm?pagename=US-Cell-Tower-Companies-Complete-List

² <http://www.ctia.org/advocacy/research/index.cfm/aid/10323>

³ <http://www.gsm.org/technology/index.htm>

⁴ <http://www.tiaonline.org/standards/technology/cdma2000/documents/TIA-EIA-IS-2001-1-B.pdf>

⁵ <http://www.3gpp.org/>

⁶ <http://www.cdg.org/>

⁷ <http://www.3gpp.org/article/lte/>

⁸ <http://www.wimaxforum.org/>

⁹ http://www.itu.int/ITU-D/imt-2000/Documents/IMT2000/What_really_3G.pdf